

We Tame Photons to Work for You!

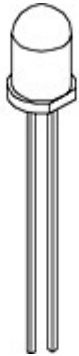

Products > LEDs > Thru-Hole > Round > 5mm > Standard > High Intensity



### Features / Options

- ▶ State-of-the-Art, High Brightness Chip Technology
- ▶ Choice of Colors and Lens Finishes
- ▶ Lead Frame / Lens Casting Reliability
- ▶ Easy-to-Solder Leads, Tin Finish
- ▶ Available Bulk or on Tape and Reel
- ▶ Lead Trimming and Forming Available
- ▶ Custom Shapes, Easily Tooled, Low Minimum

### Applications / Uses

- ▶ Board or Panel Indication or Illumination
- ▶ Annunciator and Control Panels
- ▶ Telecom Switches and Central Station Equipment
- ▶ Large Panel Indicators

Part Number:	Brightness	Dice Material	Emitted Color	Peak Wavelength	Epoxy Lens	Operating Typ Vf (V)	Intensity Typ, mcd @ 20 mA	View Angle 2x Theta	
SSL-LX5093PC	HIGH	InGaN	Pink	-	Clear	3.5	2200	20	—
SSL-LX5093PGD	STANDARD	GaP	Green	555	Diffused	2.1	30	60	—
SSL-LX5093PGT	STANDARD	GaP	Green	555	Color Tinted	2.0	50	30	—
SSL-LX5093SIC	HIGH	AllnGaP	Red	636	Clear	2.0	1800	30	—
SSL-LX5093SID	HIGH	AllnGaP	Red	636	Diffused	2.0	700	60	—
SSL-LX5093SOC	HIGH	AllnGaP	Orange	610	Clear	2.0	2500	30	—
SSL-LX5093SOD	HIGH	AllnGaP	Orange	610	Diffused	2.0	850	60	—
SSL-LX5093SRC/DU	STANDARD	GaAlAs	Red	660	Clear	1.7	1300	30	—
SSL-LX5093SRC/DV	STANDARD	GaAlAs	Red	660	Clear	1.7	1600	30	—
SSL-LX5093SRC/DW	STANDARD	GaAlAs	Red	660	Clear	1.7	2000	30	—

SSL-LX5093SRC/E		STANDARD	GaAlAs	Red	660	Clear	1.7	3500	30		—
SSL-LX5093SUGC		HIGH	AlInGaP	Green	574	Clear	2.2	1000	30		—
SSL-LX5093SUGD		HIGH	AlInGaP	Green	574	Diffused	2.2	170	60		—
SSL-LX5093SYC		HIGH	AlInGaP	Yellow	590	Clear	2.0	1000	30		—
SSL-LX5093SYD		HIGH	AlInGaP	Yellow	590	Diffused	2.0	300	60		—
SSL-LX5093TC		HIGH	InGaN	Turquoise	-	Clear	3.5	2200	20		—
SSL-LX5093UEGC		HIGH	InGaN	Green	505	Clear	3.5	1500	30		—
SSL-LX5093UPGC/C		HIGH	InGaN	Green	525	Clear	4.0	4500	20		—
SSL-LX5093UPGC/D		HIGH	InGaN	Green	525	Clear	3.7	14000	20		—
SSL-LX5093UPGD/D		HIGH	InGaN	Green	525	Diffused	3.5	2800	60		—
SSL-LX5093USBC		HIGH	InGaN	Blue	470	Clear	3.5	1000	30		—
SSL-LX5093USBD		HIGH	InGaN	Blue	470	Diffused	3.5	300	60		—
SSL-LX5093UWC/A		HIGH	InGaN	White	-	Clear	3.5	900	20		—
SSL-LX5093UWC/G		HIGH	InGaN	White	-	Clear	3.5	11000	20		—
SSL-LX5093UWW		HIGH	InGaN	White	-	Diffused	3.5	800	20		—
SSL-LX5093VC		HIGH	InGaN	Purple	-	Clear	3.5	2200	20		—

UNCONTROLLED DOCUMENT

PART NUMBER		REV.
SSL-LX5093SYC		E
REV.	E.C.N. NUMBER AND REVISION COMMENTS	DATE
A	UPDATED SPECS.	12.20.94
B	UPDATED SPECS.	12.19.95
C	E.C.N. #10204.	7.8.96
D	E.C.N. #10BRDR. & REDRAWN IN 3D.	5.31.01
E	E.C.N. #11148.	01.25.07

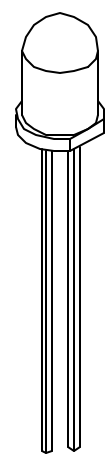
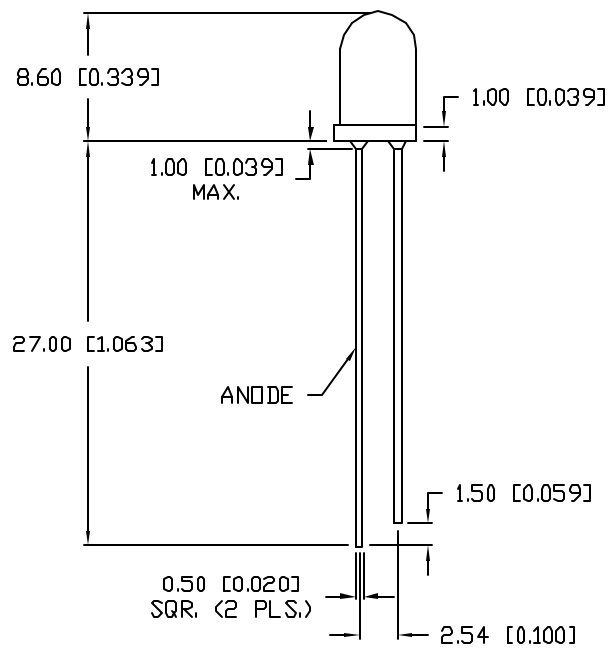
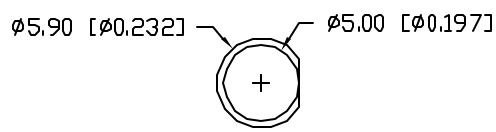

ELECTRO-OPTICAL CHARACTERISTICS  $T_A=25^{\circ}\text{C}$   $I_f=20\text{mA}$

PARAMETER	MIN	TYP	MAX	UNITS	TEST COND
PEAK WAVELENGTH		590		nm	
FORWARD VOLTAGE		2.1	2.5	$V_f$	
REVERSE VOLTAGE	5.0			$V_r$	$I_f=100\mu\text{A}$
AXIAL INTENSITY		1000		mcad	$I_f=20\text{mA}$
VIEWING ANGLE		30		2x theta	
EMITTED COLOR:	YELLOW				
EPOXY LENS FINISH:	WATER CLEAR				

LIMITS OF SAFE OPERATION AT 25°C

PARAMETER	MAX	UNITS
PEAK FORWARD CURRENT*	150	mA
STEADY CURRENT	30	mA
POWER DISSIPATION	105	mW
DERATE FROM 25°C	-1.2	mW/°C
OPERATING, STORAGE TEMP.	-40 TO +85	°C
SOLDERING TEMP.	+260	°C
2.0mm FROM BODY		3 SEC. MAX
* $t < 10\mu\text{s}$		



UNCONTROLLED DOCUMENT

\*UNLESS OTHERWISE SPECIFIED TOLERANCES PER DECIMAL PRECISION ARE: X=±1 (±0.039), XX=±0.5 (±0.020), XXX=±0.25 (±0.010), XXXX=±0.127 (±0.005). LEAD SIZE=±0.05 (±0.002), LEAD LENGTH=±0.75 (±0.030). MIN= <sup>+0.00</sup> -0.00 DECIMAL PRECISION MAX.= <sup>+0.00</sup> -0.00 DECIMAL PRECISION

REV. E	PART NUMBER SSL-LX5093SYC	<p>CONFIDENTIAL INFORMATION</p> <p>THE INFORMATION CONTAINED IN THIS DOCUMENT IS THE PROPERTY OF LUMEX INC. EXCEPT AS SPECIFICALLY AUTHORIZED IN WRITING BY LUMEX INC., THE HOLDER OF THIS DOCUMENT SHALL KEEP ALL INFORMATION CONTAINED HEREIN CONFIDENTIAL AND SHALL PROTECT SAME IN WHOLE OR IN PART FROM DISCLOSURE AND DISSEMINATION TO ALL THIRD PARTIES.</p> <p>RELIABILITY NOTE</p> <p>OUR MANY YEARS OF EXPERIENCE DATA ACCUMULATION INDICATE THAT SOLDER HEAT IS A MAJOR CAUSE OF EARLY AND FUTURE FAILURE. PLEASE PAY ATTENTION TO YOUR SOLDERING PROCESS.</p>	
T-5mm (T-1 3/4) 590nm SUPER YELLOW LED, WATER CLEAR LENS.		DRAWN BY: JC CHECKED BY: APPROVED BY:	DATE: 4.5.93 PAGE: 1 OF 1 SCALE: N/A